

# Automatic thermoformer

## Print project

Serial number : \_\_\_\_\_

Customer : \_\_\_\_\_

Mold : 1x1

Width film : 470 mm

Diameter max : 320 mm

Core Ø Int : 76 mm

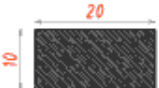
Tolerances		Printing sign size
Film type	Tolerances per 1m lineal	
Do not stretch	-1 to 3 mm	
Normally Stretch	-2 to 5 mm	
Very soft	-4 to -8 mm	Colour: Black

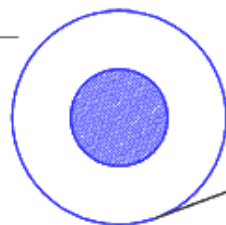

Film

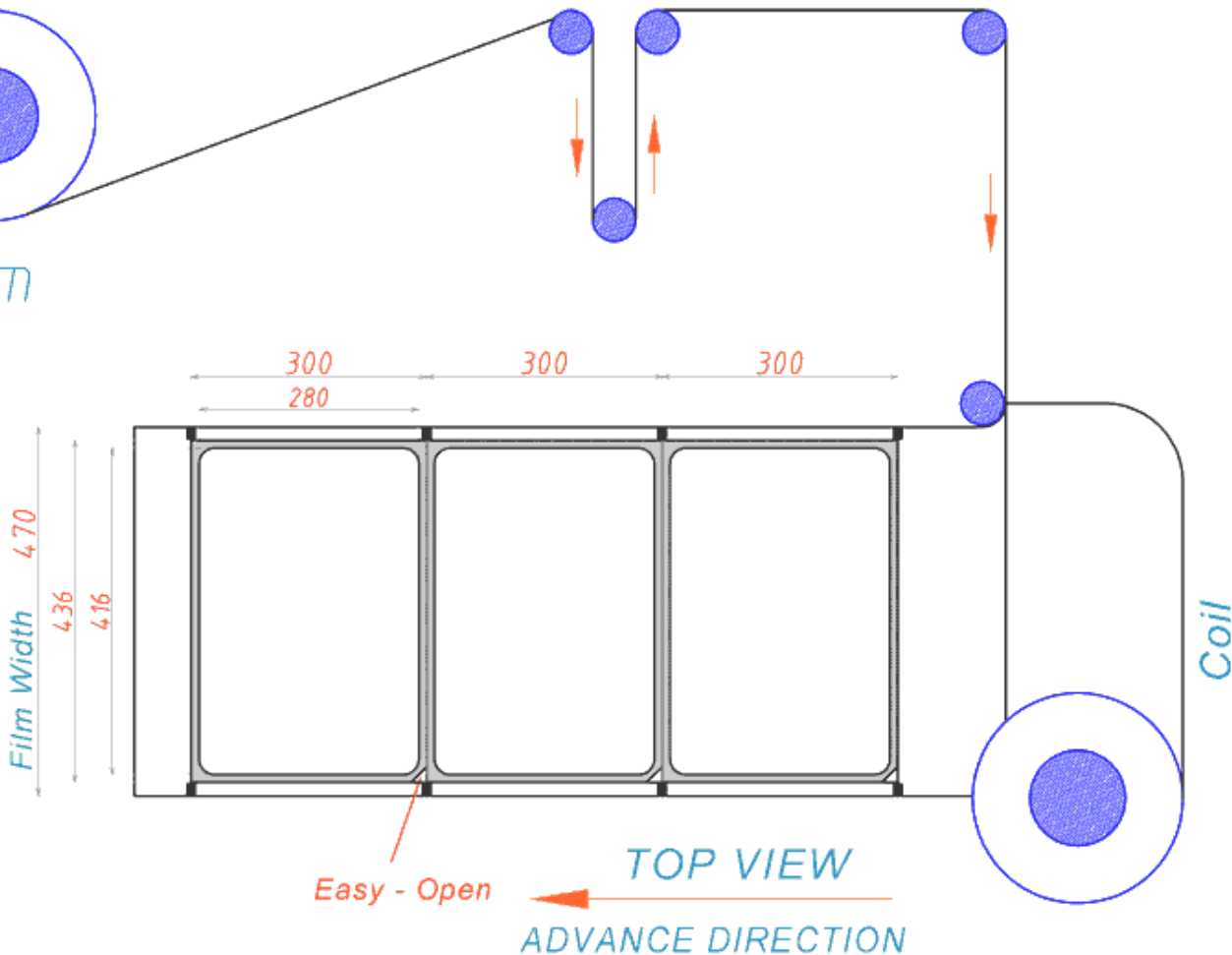

FILM MANUFACTURER SHOULD REQUEST CONTAINER SAMPLES TO THE CUSTOMER TO CHECK MEASURES OF THE RADIUS, WIDTH AND LENGTH OF THE CONTAINERS, AS WELL AS THE CHECKING OF THE EASY OPEN PLACEMENT.

That measures are the real in the machine mechanized - FRIMAQ is not responsible of possibles disturbances in the impressions caused by elongation or shrinkage caused by the quality of the film

# Automatic thermoformer

## Print project

Serial number : \_\_\_\_\_

Customer : \_\_\_\_\_

Mold : \_\_\_\_\_ 1x2 \_\_\_\_\_

Width film : \_\_\_\_\_ 470 mm \_\_\_\_\_

Diameter max : \_\_\_\_\_ 320 mm \_\_\_\_\_

Core Ø Int : \_\_\_\_\_ 76 mm \_\_\_\_\_

Tolerances		Printing sign size
Film type	Tolerances per 1m lineal	
Do not stretch	-1 to 3 mm	
Normally Stretch	-2 to 5 mm	
Very soft	-4 to -8 mm	Colour: Black

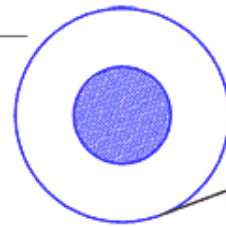

Film

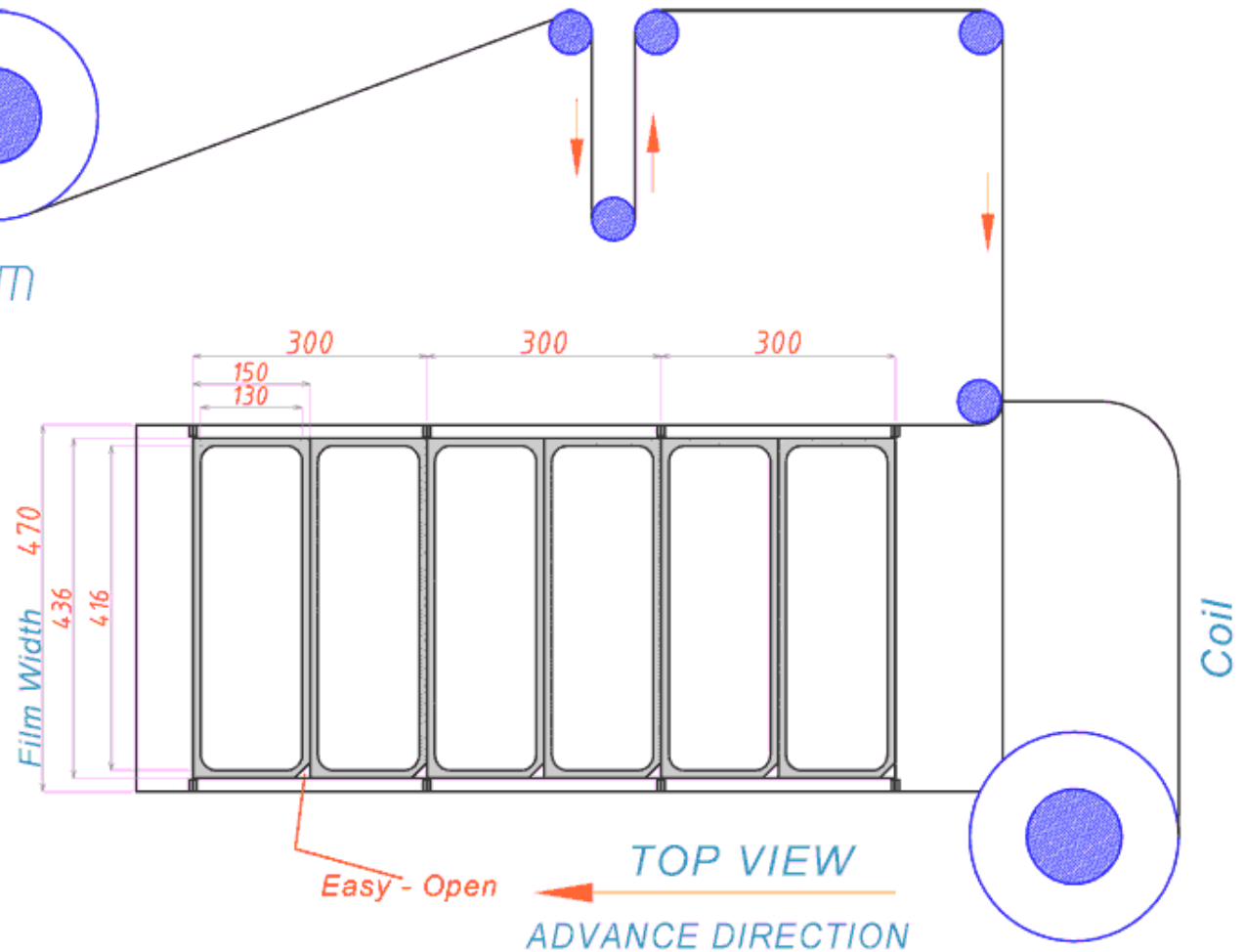

FILM MANUFACTURER SHOULD REQUEST CONTAINER SAMPLES TO THE CUSTOMER TO CHECK MEASURES OF THE RADIUS, WIDTH AND LENGTH OF THE CONTAINERS, AS WELL AS THE CHECKING OF THE EASY OPEN PLACEMENT.

That measures are the real in the machine mechanized - FRIMAQ is not responsible of possibles disturbances in the impressions caused by elongation or shrinkage caused by the quality of the film

# Automatic thermoformer

## Print project

Serial number : \_\_\_\_\_

Customer : \_\_\_\_\_

Mold : \_\_\_\_\_ 2x1 \_\_\_\_\_

Width film : \_\_\_\_\_ 470 mm \_\_\_\_\_

Diameter max : \_\_\_\_\_ 320 mm \_\_\_\_\_

Core Ø Int : \_\_\_\_\_ 76 mm \_\_\_\_\_

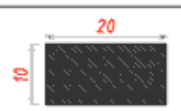
Tolerances		Printing sign size
Film type	Tolerances per 1m lineal	
Do not stretch	-1 to 3 mm	
Normally Stretch	-2 to 5 mm	
Very soft	-4 to -8 mm	Colour: Black

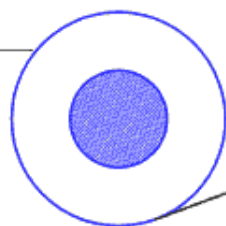

Film

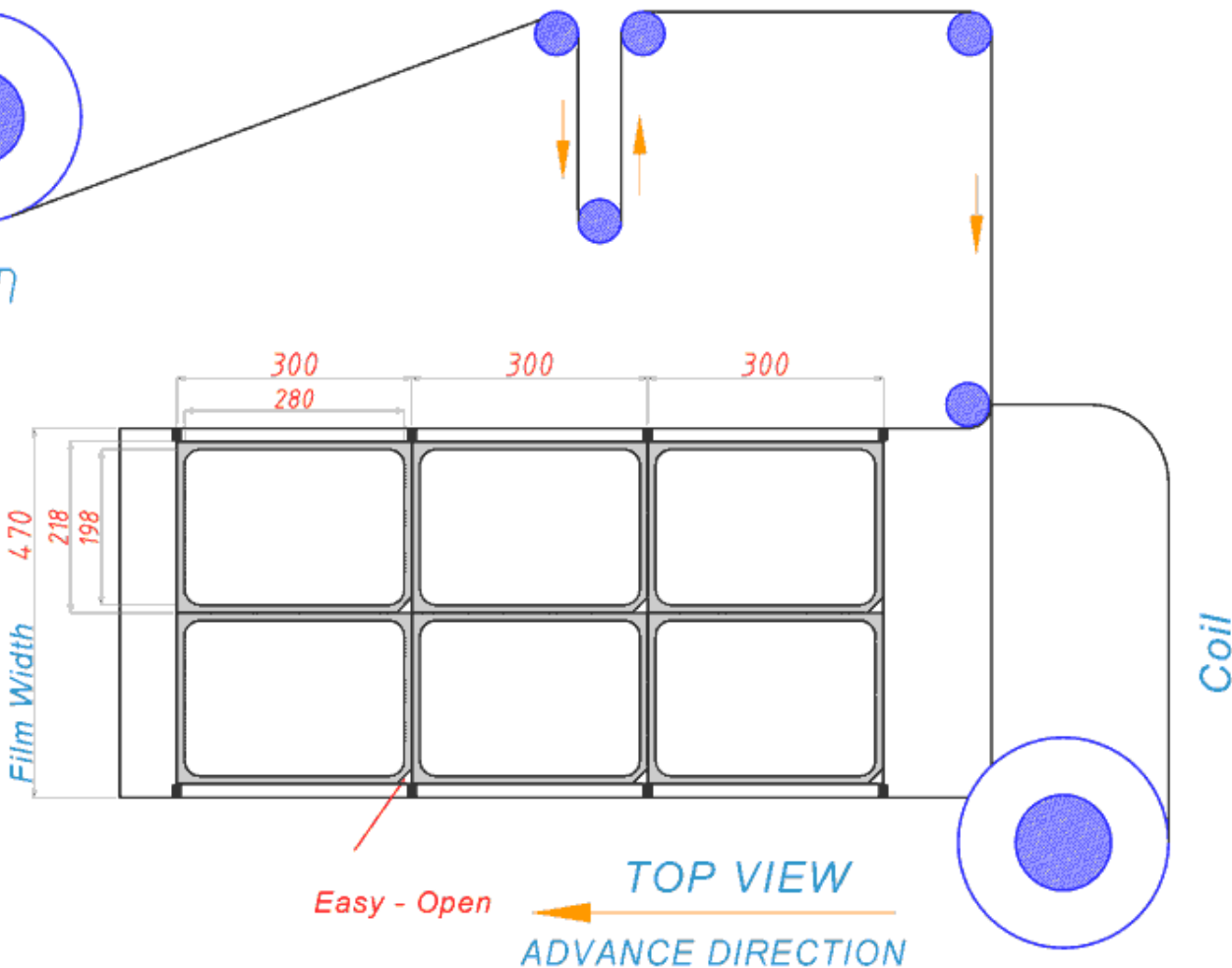

FILM MANUFACTURER SHOULD REQUEST CONTAINER SAMPLES TO THE CUSTOMER TO CHECK MEASURES OF THE RADIUS, WIDTH AND LENGTH OF THE CONTAINERS, AS WELL AS THE CHECKING OF THE EASY OPEN PLACEMENT.

That measures are the real in the machine mechanized - FRIMAQ is not responsible of possibles disturbances in the impressions caused by elongation or shrinkage caused by the quality of the film

# Automatic thermoformer

## Print project

Serial number : \_\_\_\_\_  
 Customer : \_\_\_\_\_  
 Mold : \_\_\_\_\_ *2x2* \_\_\_\_\_  
 Width film : \_\_\_\_\_ *470 mm* \_\_\_\_\_  
 Diameter max : \_\_\_\_\_ *320 mm* \_\_\_\_\_  
 Core Ø Int : \_\_\_\_\_ *76 mm* \_\_\_\_\_

Tolerances		Printing sign size
Film type	Tolerances per 1m lineal	
Do not stretch	-1 to 3 mm	
Normally Stretch	-2 to 5 mm	
Very soft	-4 to -8 mm	Colour: Black

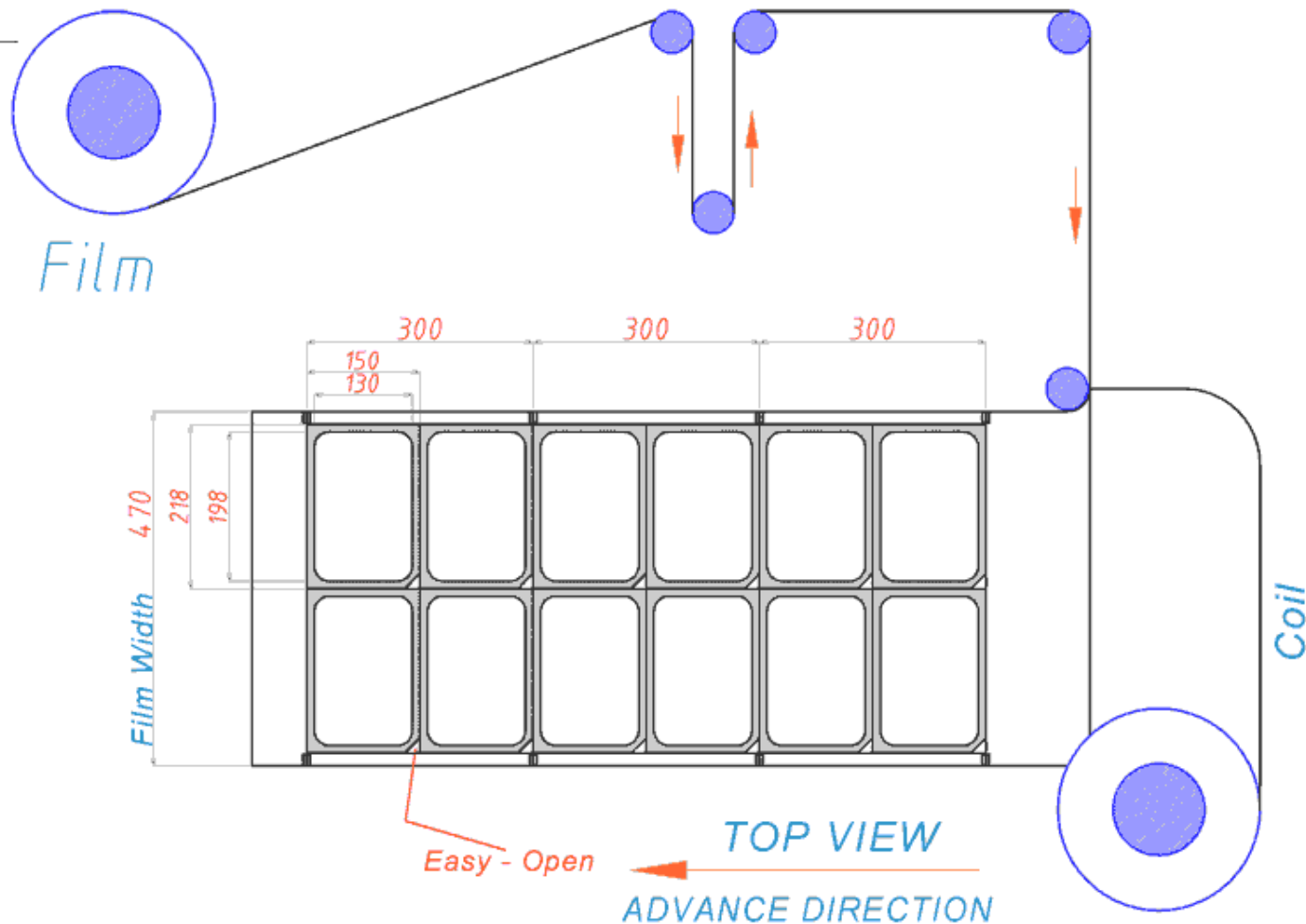

FILM MANUFACTURER SHOULD REQUEST CONTAINER SAMPLES TO THE CUSTOMER TO CHECK MEASURES OF THE RADIUS, WIDTH AND LENGTH OF THE CONTAINERS, AS WELL AS THE CHECKING OF THE EASY OPEN PLACEMENT.

That measures are the real in the machine mechanized - FRIMAQ is not responsible of possibles disturbances in the impressions caused by elongation or shrinkage caused by the quality of the film

# Automatic thermoformer

## Print project

Serial number : \_\_\_\_\_  
 Customer : \_\_\_\_\_  
 Mold : \_\_\_\_\_ 3x1 \_\_\_\_\_  
 Width film : \_\_\_\_\_ 470 mm \_\_\_\_\_  
 Diameter max : \_\_\_\_\_ 320 mm \_\_\_\_\_  
 Core Ø Int : \_\_\_\_\_ 76 mm \_\_\_\_\_

Tolerances		Printing sign size
Film type	Tolerances per 1m lineal	
Do not stretch	-1 to 3 mm	
Normally Stretch	-2 to 5 mm	
Very soft	-4 to -8 mm	Colour: Black

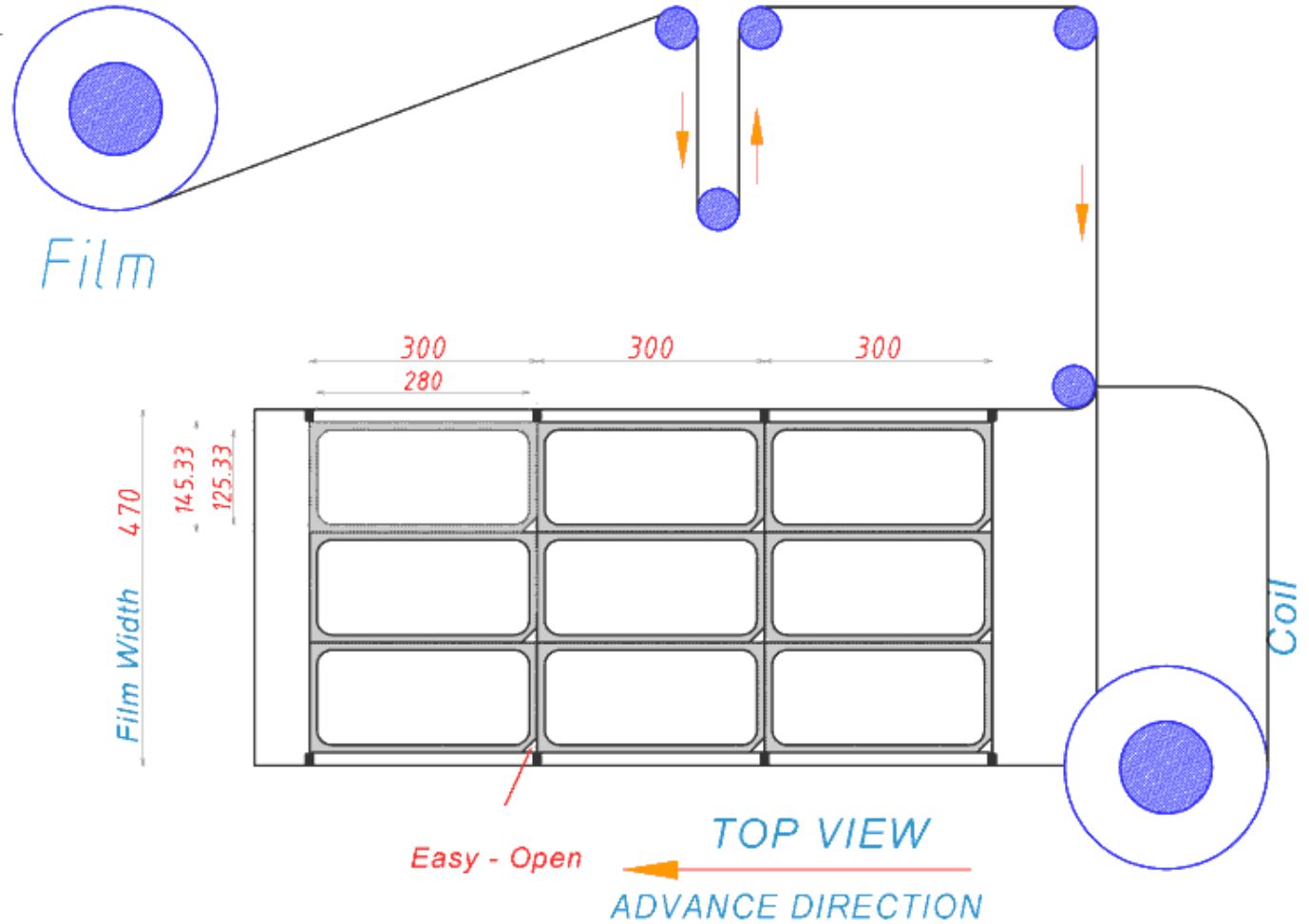

FILM MANUFACTURER SHOULD REQUEST CONTAINER SAMPLES TO THE CUSTOMER TO CHECK MEASURES OF THE RADIUS, WIDTH AND LENGTH OF THE CONTAINERS, AS WELL AS THE CHECKING OF THE EASY OPEN PLACEMENT.

That measures are the real in the machine mechanized - FRIMAQ is not responsible of possibles disturbances in the impressions caused by elongation or shrinkage caused by the quality of the film

# Automatic thermoformer

## Print project

Serial number : \_\_\_\_\_

Customer : \_\_\_\_\_

Mold : \_\_\_\_\_ 3x2 \_\_\_\_\_

Width film : \_\_\_\_\_ 470 mm \_\_\_\_\_

Diameter max : \_\_\_\_\_ 320 mm \_\_\_\_\_

Core Ø Int : \_\_\_\_\_ 76 mm \_\_\_\_\_

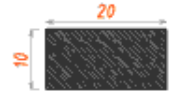
Tolerances		Printing sign size
Film type	Tolerances per 1m lineal	
Do not stretch	-1 to 3 mm	
Normally Stretch	-2 to 5 mm	
Very soft	-4 to -8 mm	Colour: Black

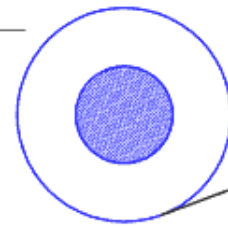

Film

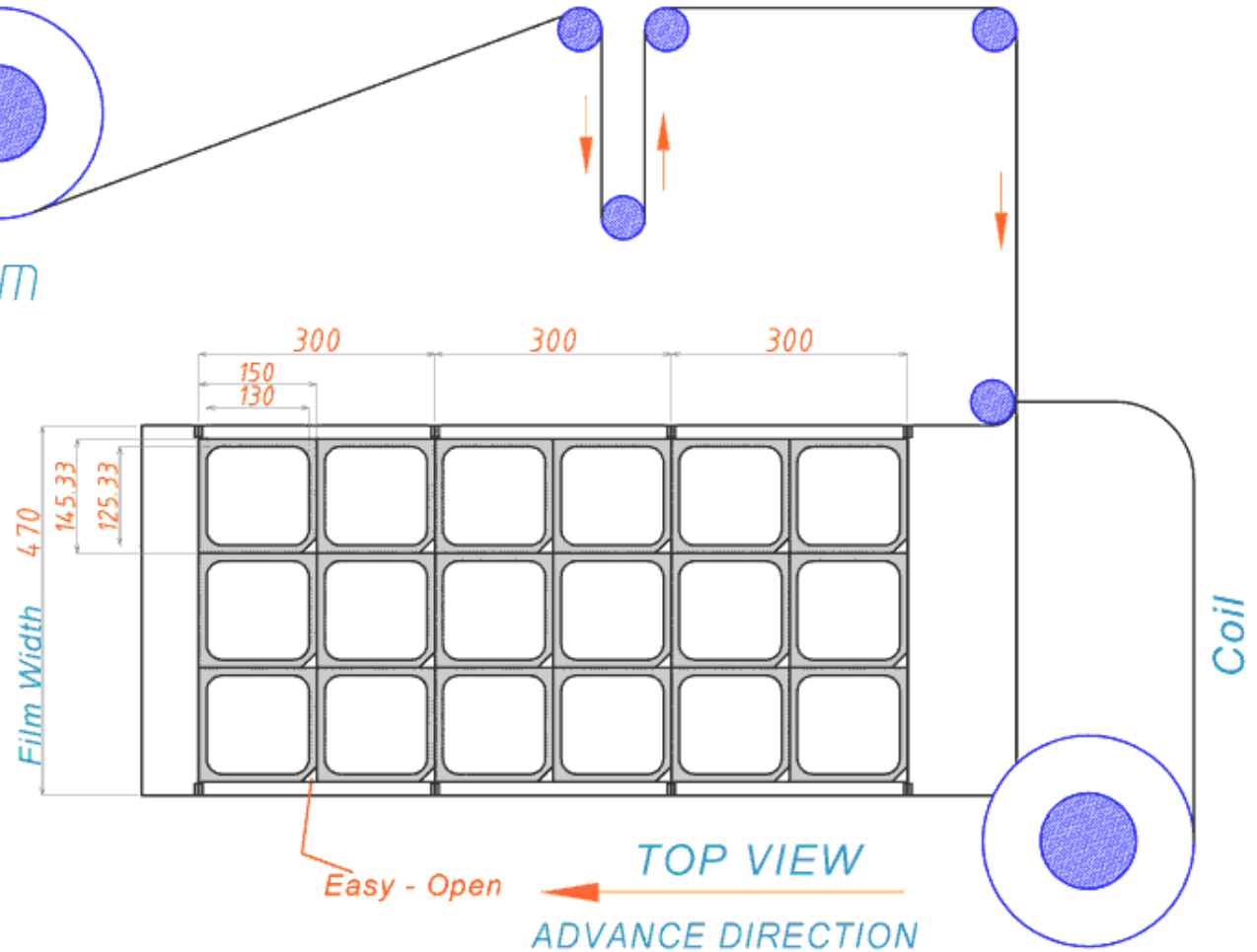

FILM MANUFACTURER SHOULD REQUEST CONTAINER SAMPLES TO THE CUSTOMER TO CHECK MEASURES OF THE RADIUS, WIDTH AND LENGTH OF THE CONTAINERS, AS WELL AS THE CHECKING OF THE EASY OPEN PLACEMENT.

That measures are the real in the machine mechanized - FRIMAQ is not responsible of possibles disturbances in the impressions caused by elongation or shrinkage caused by the quality of the film

# Automatic thermoformer

## Print project

Serial number : \_\_\_\_\_  
 Customer : \_\_\_\_\_  
 Mold : 4x1  
 Width film : 470 mm  
 Diameter max : 320 mm  
 Core Ø Int : 76 mm

Tolerances		Printing sign size
Film type	Tolerances per 1m lineal	
Do not stretch	-1 to 3 mm	
Normally Stretch	-2 to 5 mm	
Very soft	-4 to -8 mm	Colour: Black

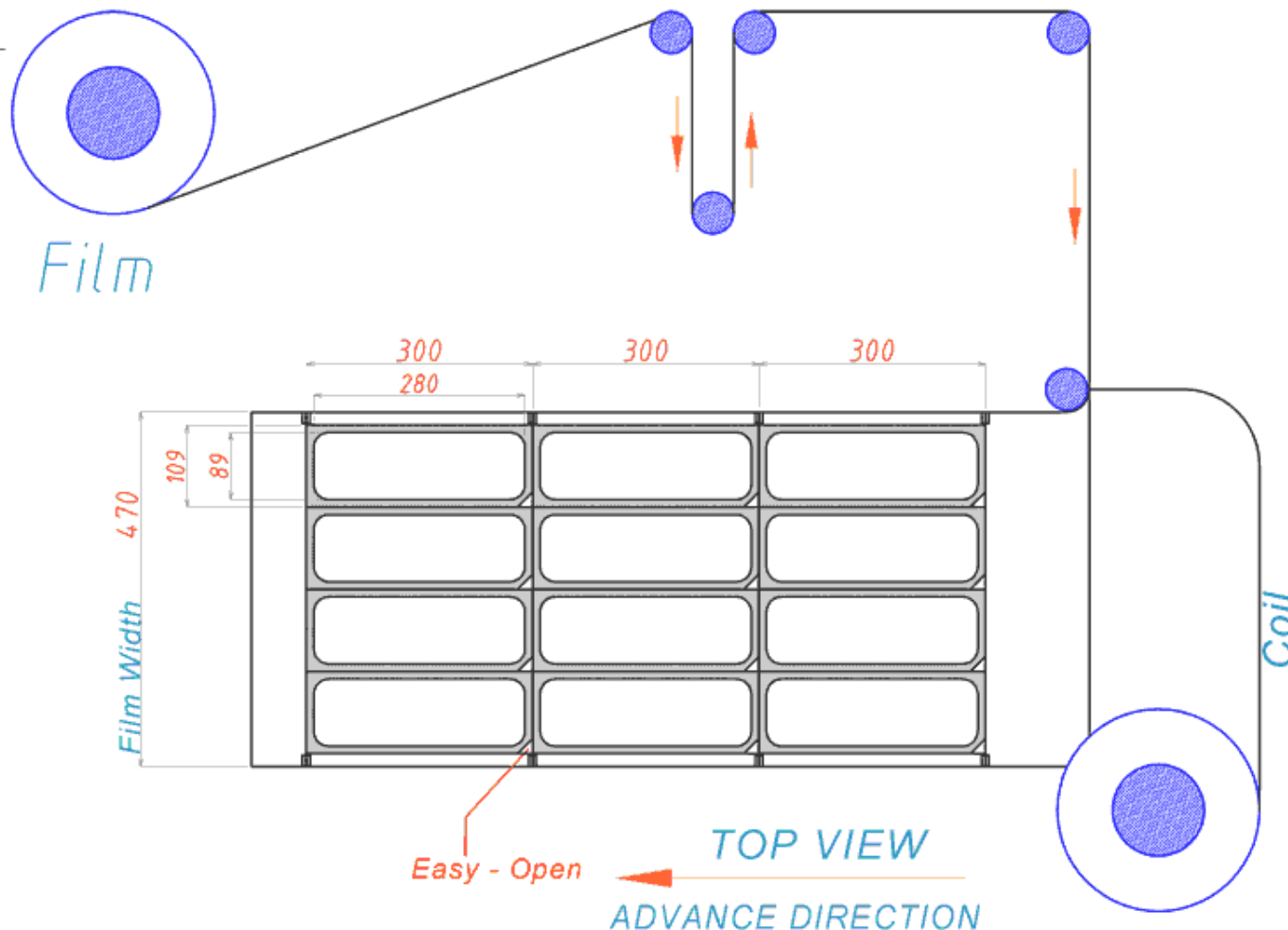

FILM MANUFACTURER SHOULD REQUEST CONTAINER SAMPLES TO THE CUSTOMER TO CHECK MEASURES OF THE RADIUS, WIDTH AND LENGTH OF THE CONTAINERS, AS WELL AS THE CHECKING OF THE EASY OPEN PLACEMENT.

That measures are the real in the machine mechanized - FRIMAQ is not responsible of possibles disturbances in the impressions caused by elongation or shrinkage caused by the quality of the film

# Automatic thermoformer

## Print project

Serial number : \_\_\_\_\_  
 Customer : \_\_\_\_\_  
 Mold : 4x2  
 Width film : 470 mm  
 Diameter max : 320 mm  
 Core Ø Int : 76 mm

Tolerances		Printing sign size
Film type	Tolerances per 1m lineal	
Do not stretch	-1 to 3 mm	
Normally Stretch	-2 to 5 mm	
Very soft	-4 to -8 mm	Colour: Black

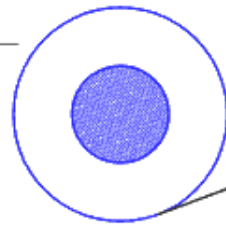

Film

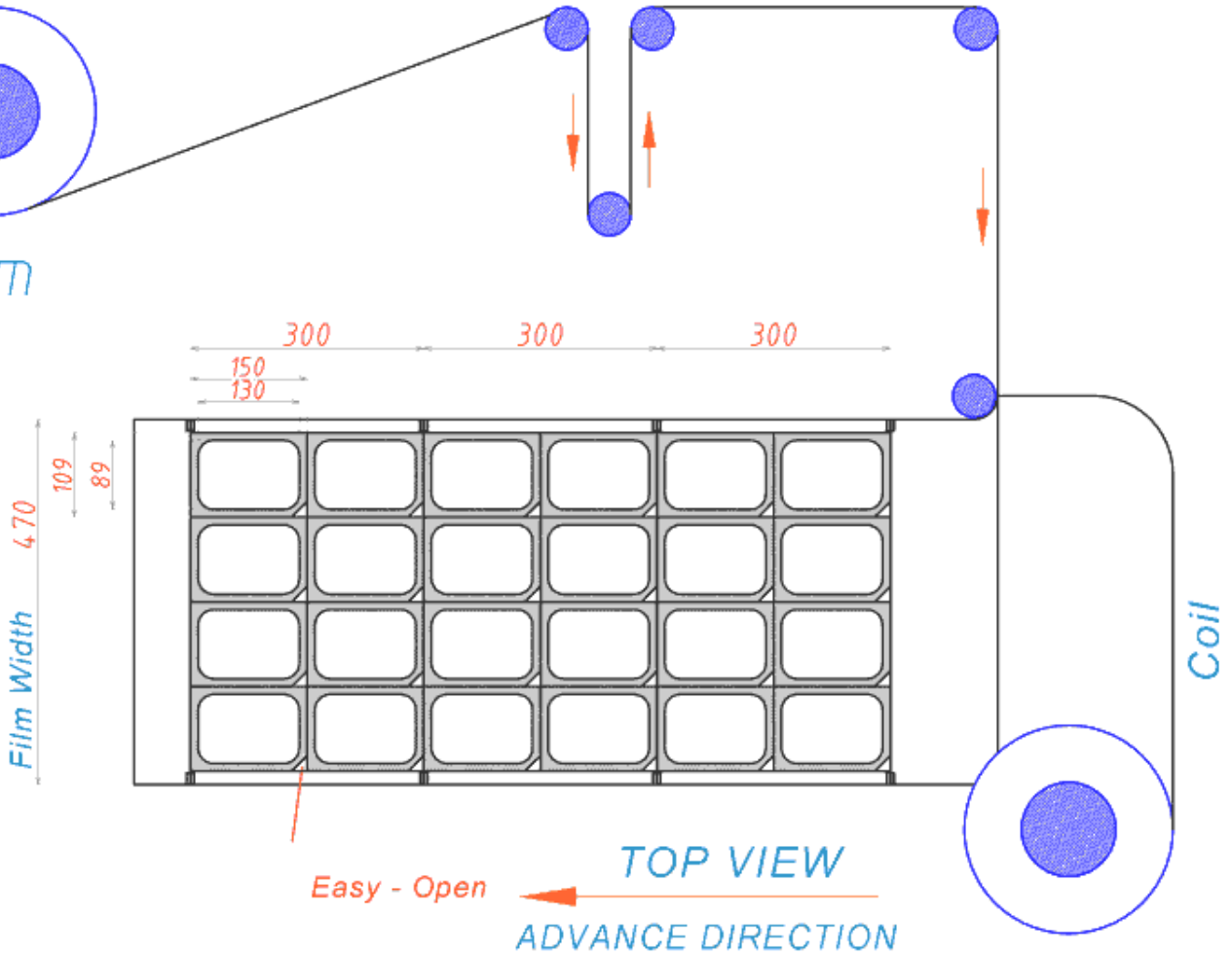

FILM MANUFACTURER SHOULD REQUEST CONTAINER SAMPLES TO THE CUSTOMER TO CHECK MEASURES OF THE RADIUS, WIDTH AND LENGTH OF THE CONTAINERS, AS WELL AS THE CHECKING OF THE EASY OPEN PLACEMENT.

That measures are the real in the machine mechanized - FRIMAQ is not responsible of possibles disturbances in the impressions caused by elongation or shrinkage caused by the quality of the film