

Automatic thermoformer

Print project

Serial number : _____

Customer : _____

Mold : - 1x1

Width film : 360 mm

Diameter max : 320 mm

Core Ø Int : 76 mm

Tolerances		Printing sign size
Film type	Tolerances per 1m lineal	
Do not stretch	-1 to 3 mm	
Normally Stretch	-2 to 5 mm	
Very soft	-4 to -8 mm	Colour: Black

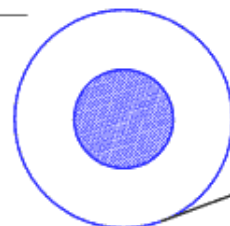

Film

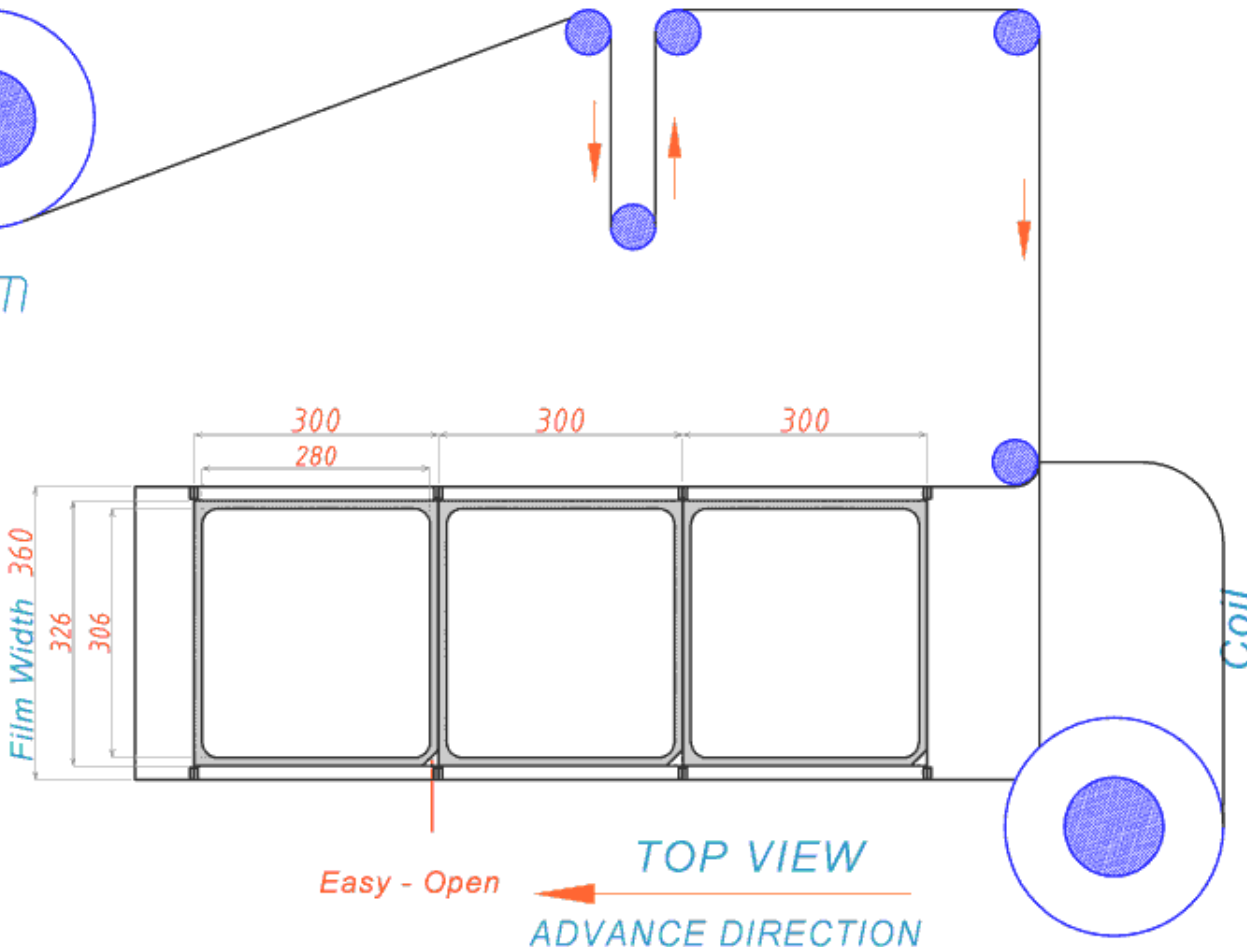

FILM MANUFACTURER SHOULD REQUEST CONTAINER SAMPLES TO THE CUSTOMER TO CHECK MEASURES OF THE RADIUS, WIDTH AND LENGTH OF THE CONTAINERS, AS WELL AS THE CHECKING OF THE EASY OPEN PLACEMENT.

That measures are the real in the machine mechanized - FRIMAQ is not responsible of possibles disturbances in the impressions caused by elongation or shrinkage caused by the quality of the film

Automatic thermoformer

Print project

Serial number : _____

Customer : _____

Mold : 1x2

Width film : 360 mm

Diameter max : 320 mm

Core Ø Int : 76 mm

Tolerances		Printing sign size
Film type	Tolerances per 1m lineal	
Do not stretch	-1 to 3 mm	
Normally Stretch	-2 to 5 mm	
Very soft	-4 to -8 mm	Colour: Black

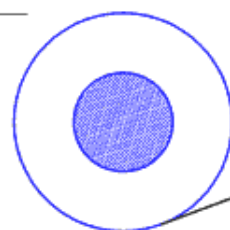

Film

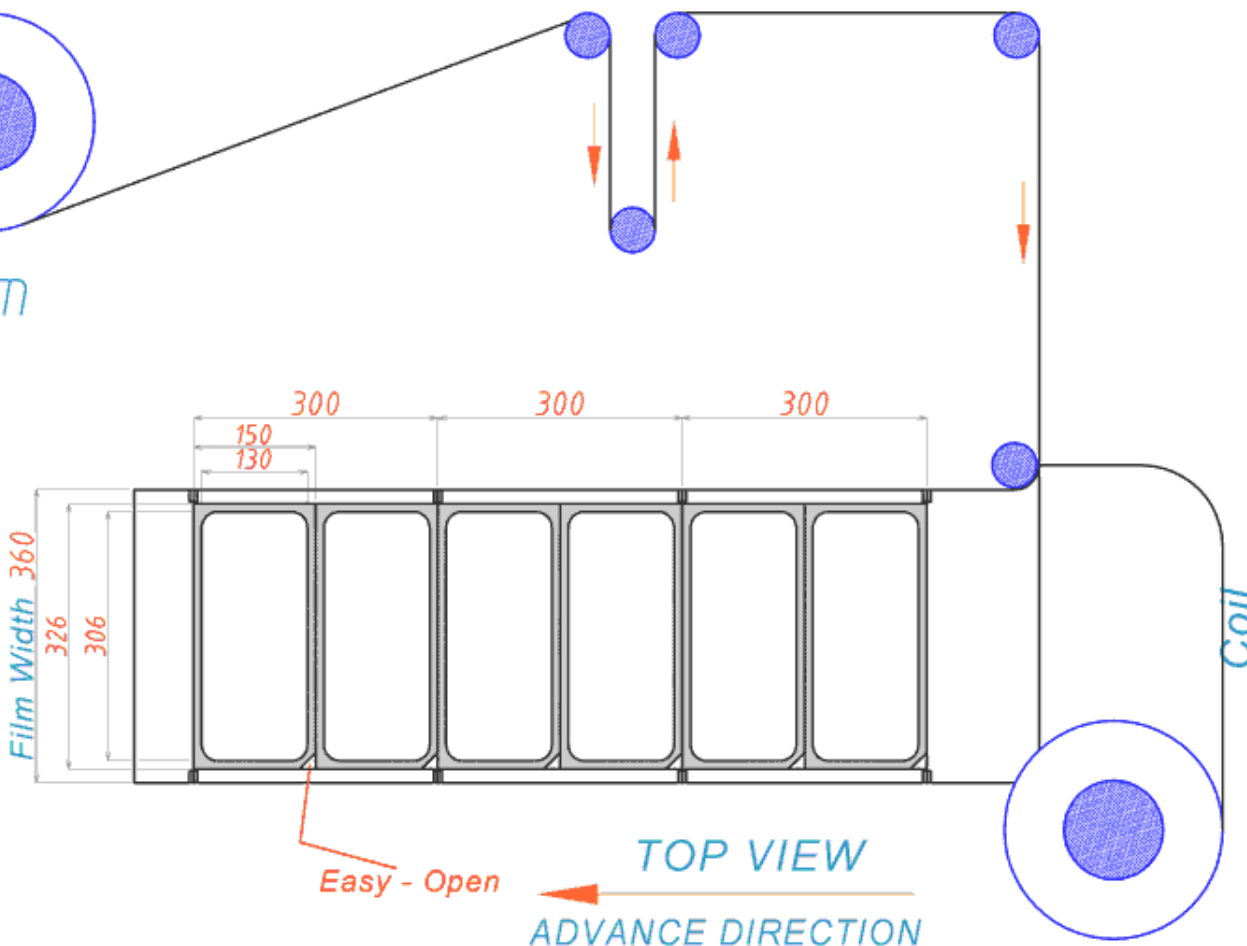

FILM MANUFACTURER SHOULD REQUEST CONTAINER SAMPLES TO THE CUSTOMER TO CHECK MEASURES OF THE RADIUS, WIDTH AND LENGTH OF THE CONTAINERS, AS WELL AS THE CHECKING OF THE EASY OPEN PLACEMENT.

That measures are the real in the machine mechanized - FRIMAQ is not responsible of possibles disturbances in the impressions caused by elongation or shrinkage caused by the quality of the film

Automatic thermoformer

Print project

Serial number : _____

Customer : _____

Mold : 2x1

Width film : 360 mm

Diameter max : 320 mm

Core Ø Int : 76 mm

Tolerances		Printing sign size
Film type	Tolerances per 1m lineal	
Do not stretch	-1 to 3 mm	
Normally Stretch	-2 to 5 mm	
Very soft	-4 to -8 mm	Colour: Black

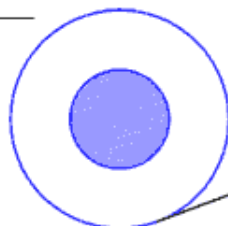

Film

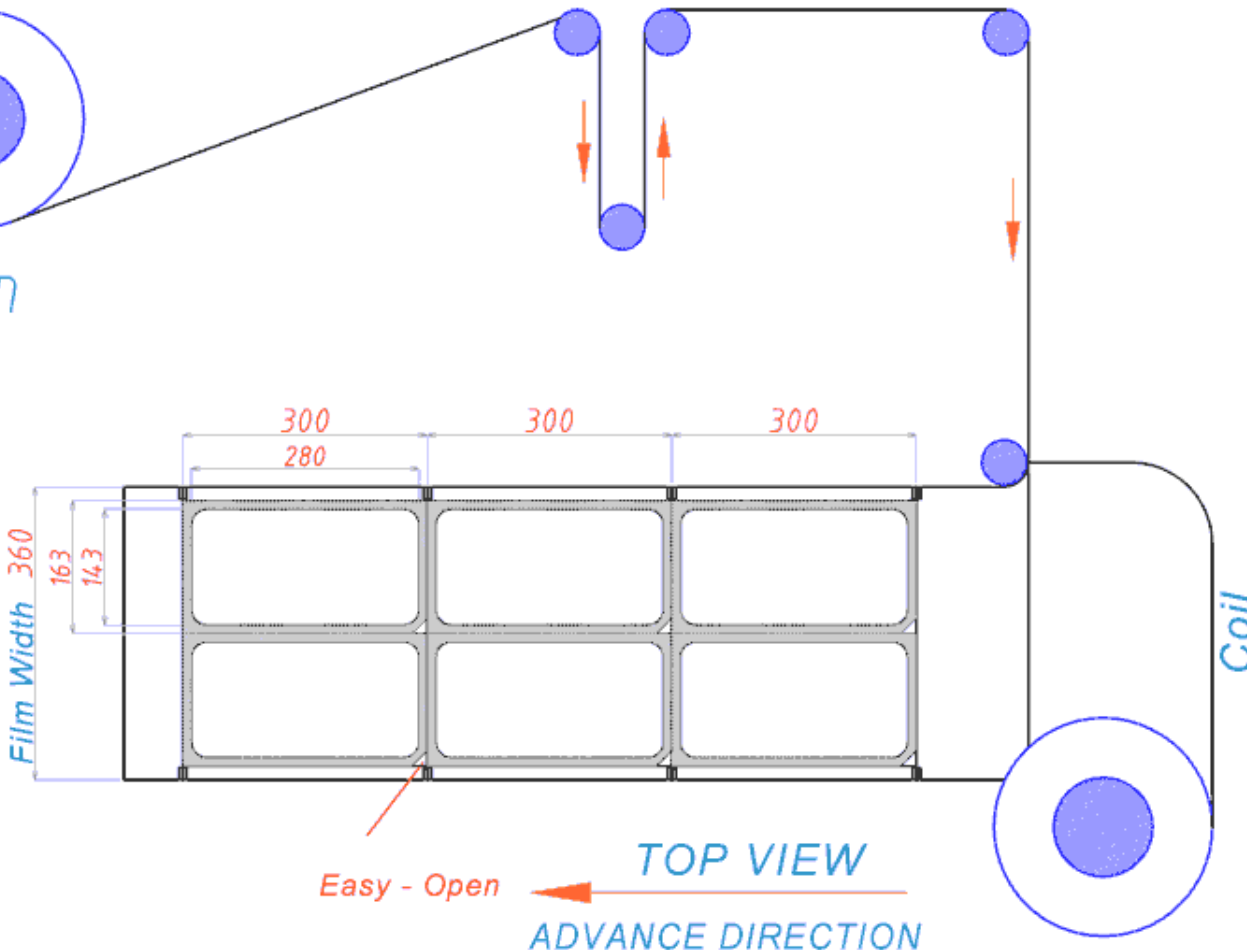

FILM MANUFACTURER SHOULD REQUEST CONTAINER SAMPLES TO THE CUSTOMER TO CHECK MEASURES OF THE RADIUS, WIDTH AND LENGTH OF THE CONTAINERS, AS WELL AS THE CHECKING OF THE EASY OPEN PLACEMENT.

That measures are the real in the machine mechanized - FRIMAQ is not responsible of possibles disturbances in the impressions caused by elongation or shrinkage caused by the quality of the film

Automatic thermoformer

Print project

Serial number : _____

Customer : _____

Mold : 2x2

Width film : 360 mm

Diameter max : 320 mm

Core Ø Int : 76 mm

Tolerances		Printing sign size 
Film type	Tolerances per 1m lineal	
Do not stretch	-1 to 3 mm	10
Normally Stretch	-2 to 5 mm	
Very soft	-4 to -8 mm	Colour: Black

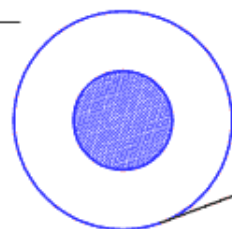

Film

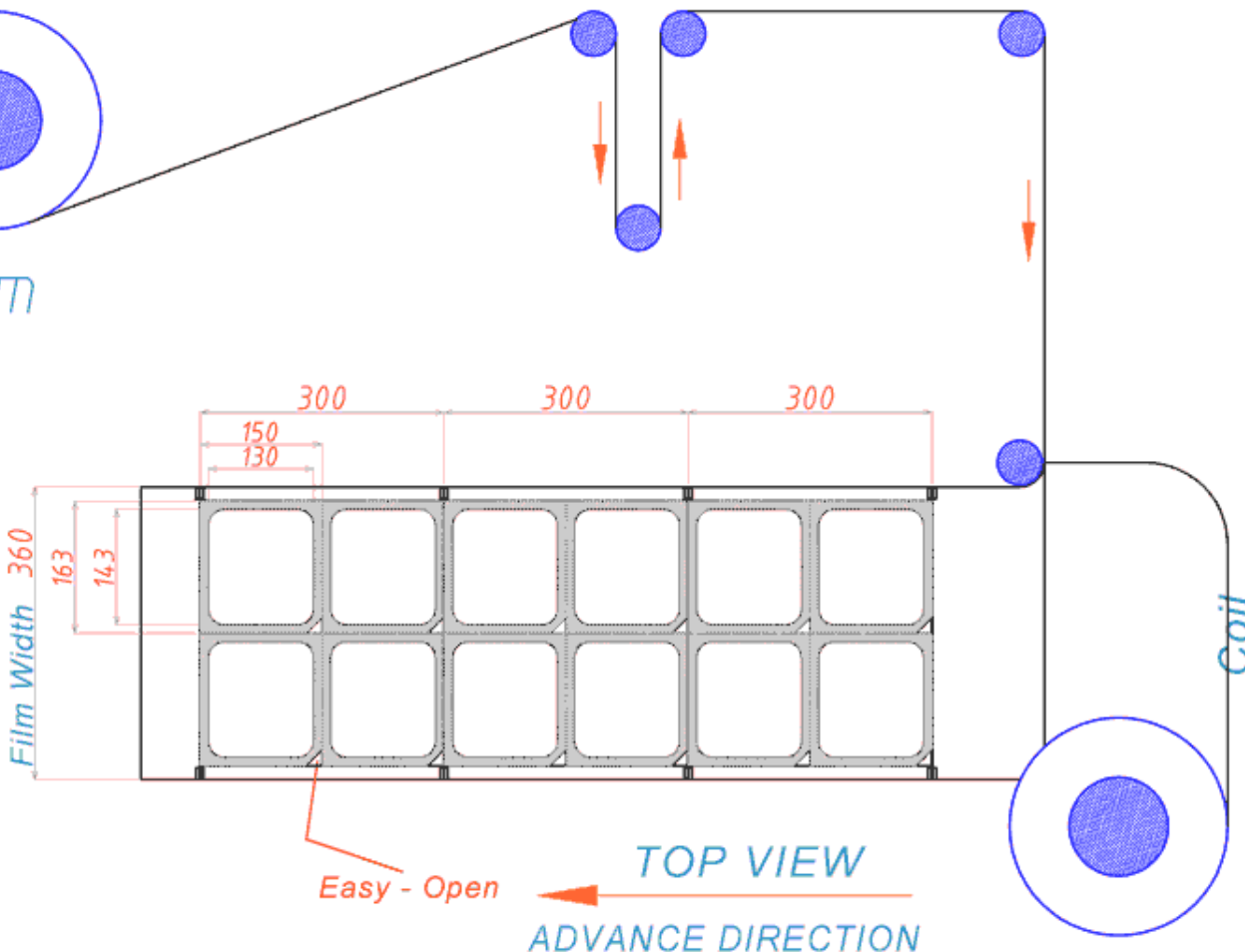

FILM MANUFACTURER SHOULD REQUEST CONTAINER SAMPLES TO THE CUSTOMER TO CHECK MEASURES OF THE RADIUS, WIDTH AND LENGTH OF THE CONTAINERS, AS WELL AS THE CHECKING OF THE EASY OPEN PLACEMENT.

That measures are the real in the machine mechanized - FRIMAQ is not responsible of possibles disturbances in the impressions caused by elongation or shrinkage caused by the quality of the film

Automatic thermoformer

Print project

Serial number : _____

Customer : _____

Mold : _____ 3x1

Width film : _____ 360 mm

Diameter max : _____ 320 mm

Core Ø Int : _____ 76 mm

Tolerances		Printing sign size
Film type	Tolerances per 1m lineal	
Do not stretch	-1 to 3 mm	
Normally Stretch	-2 to 5 mm	
Very soft	-4 to -8 mm	Colour: Black

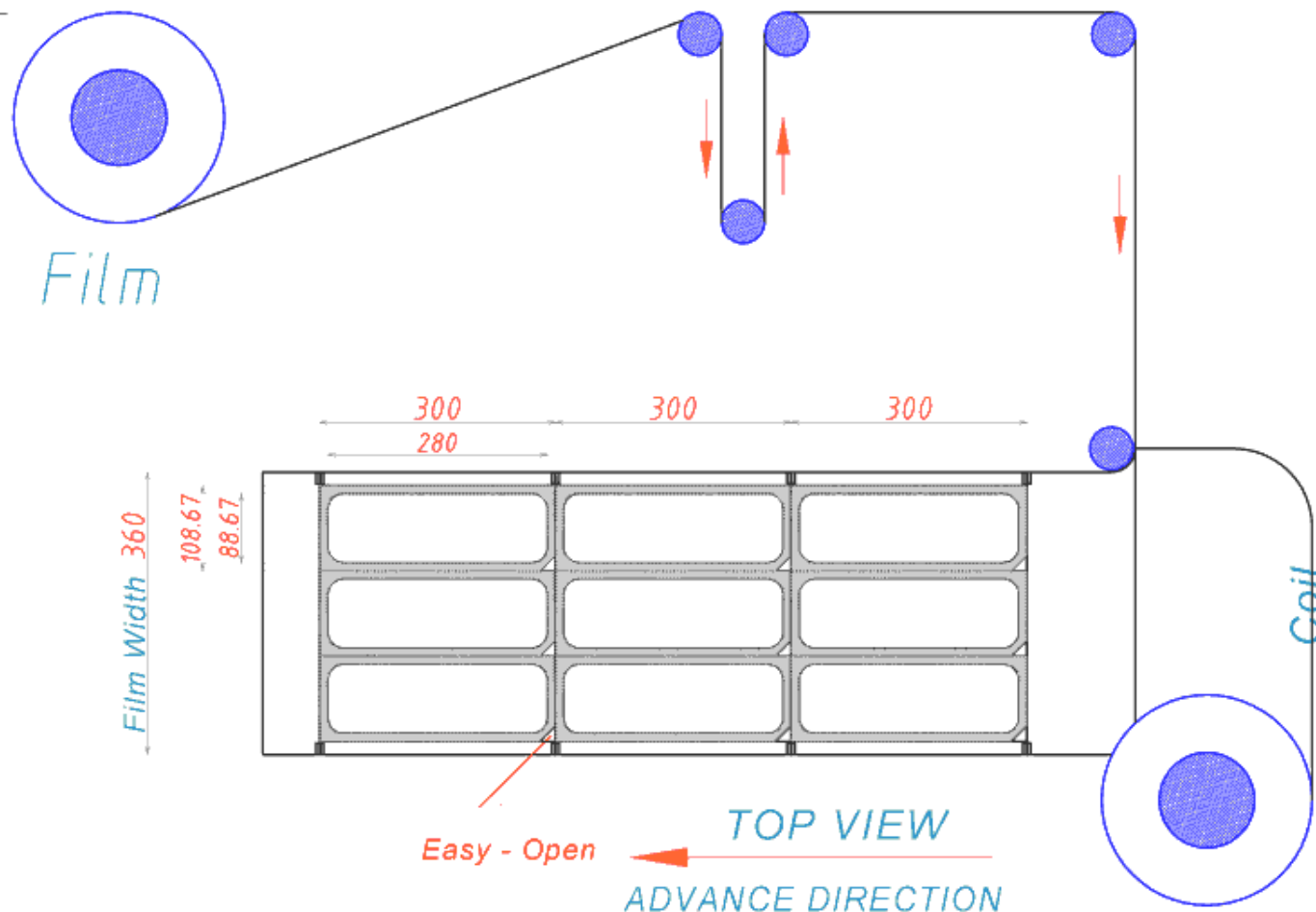

FILM MANUFACTURER SHOULD REQUEST CONTAINER SAMPLES TO THE CUSTOMER TO CHECK MEASURES OF THE RADIUS, WIDTH AND LENGTH OF THE CONTAINERS, AS WELL AS THE CHECKING OF THE EASY OPEN PLACEMENT.

That measures are the real in the machine mechanized - FRIMAQ is not responsible of possibles disturbances in the impressions caused by elongation or shrinkage caused by the quality of the film

Automatic thermoformer

Print project

Serial number : _____

Customer : _____

Mold : 3x2

Width film : 360 mm

Diameter max : 320 mm

Core Ø Int : 76 mm

Tolerances		Printing sign size
Film type	Tolerances per 1m lineal	
Do not stretch	-1 to 3 mm	
Normally Stretch	-2 to 5 mm	Colour: Black
Very soft	-4 to -8 mm	

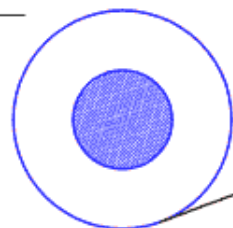

Film

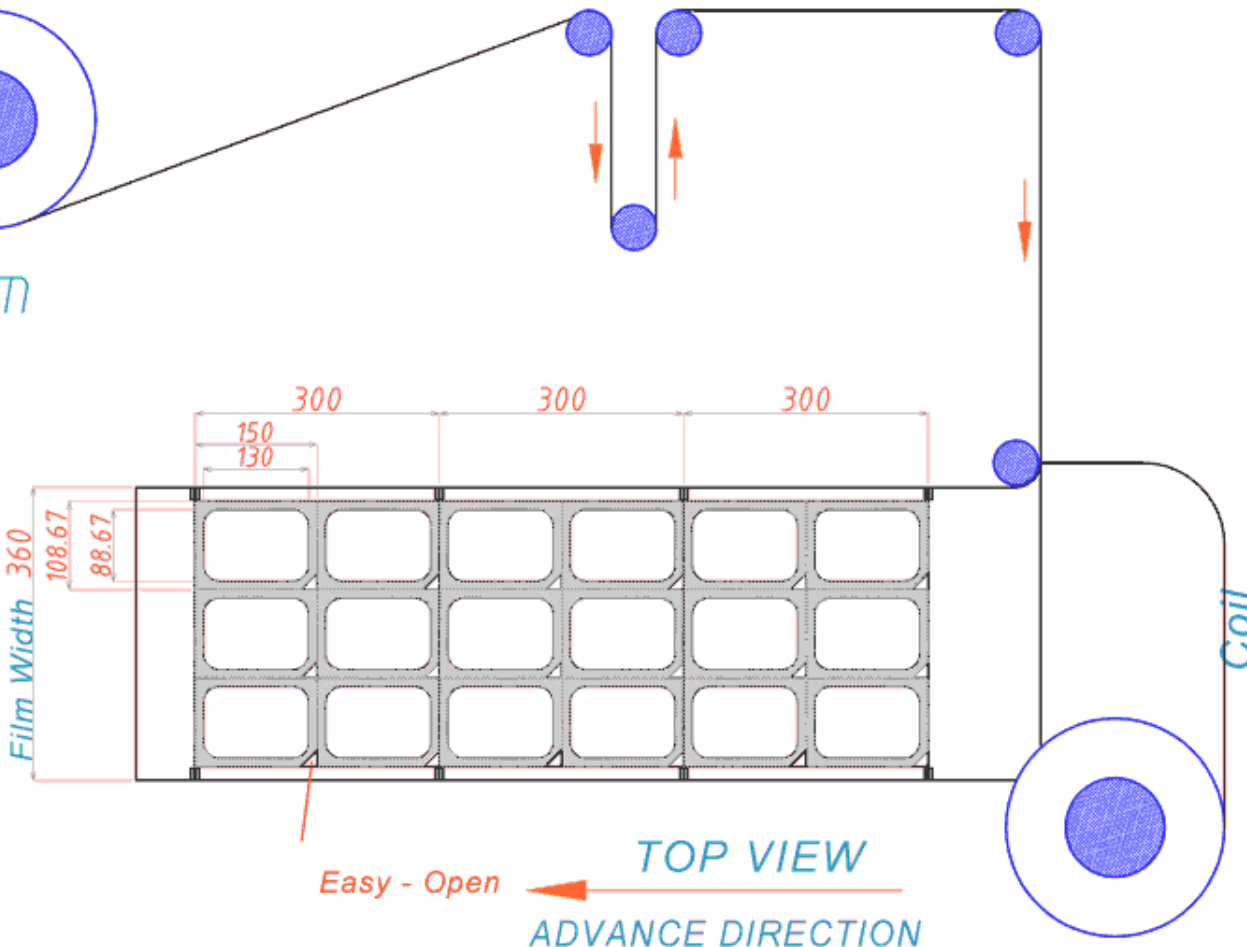

FILM MANUFACTURER SHOULD REQUEST CONTAINER SAMPLES TO THE CUSTOMER TO CHECK MEASURES OF THE RADIUS, WIDTH AND LENGTH OF THE CONTAINERS, AS WELL AS THE CHECKING OF THE EASY OPEN PLACEMENT.

That measures are the real in the machine mechanized - FRIMAQ is not responsible of possibles disturbances in the impressions caused by elongation or shrinkage caused by the quality of the film

Automatic thermoformer

Print project

Serial number : _____

Customer : _____

Mold : 4x1

Width film : 360 mm

Diameter max : 320 mm

Core Ø Int : 76 mm

Tolerances		Printing sign size
Film type	Tolerances per 1m lineal	
Do not stretch	-1 to 3 mm	
Normally Stretch	-2 to 5 mm	Colour: Black
Very soft	-4 to -8 mm	

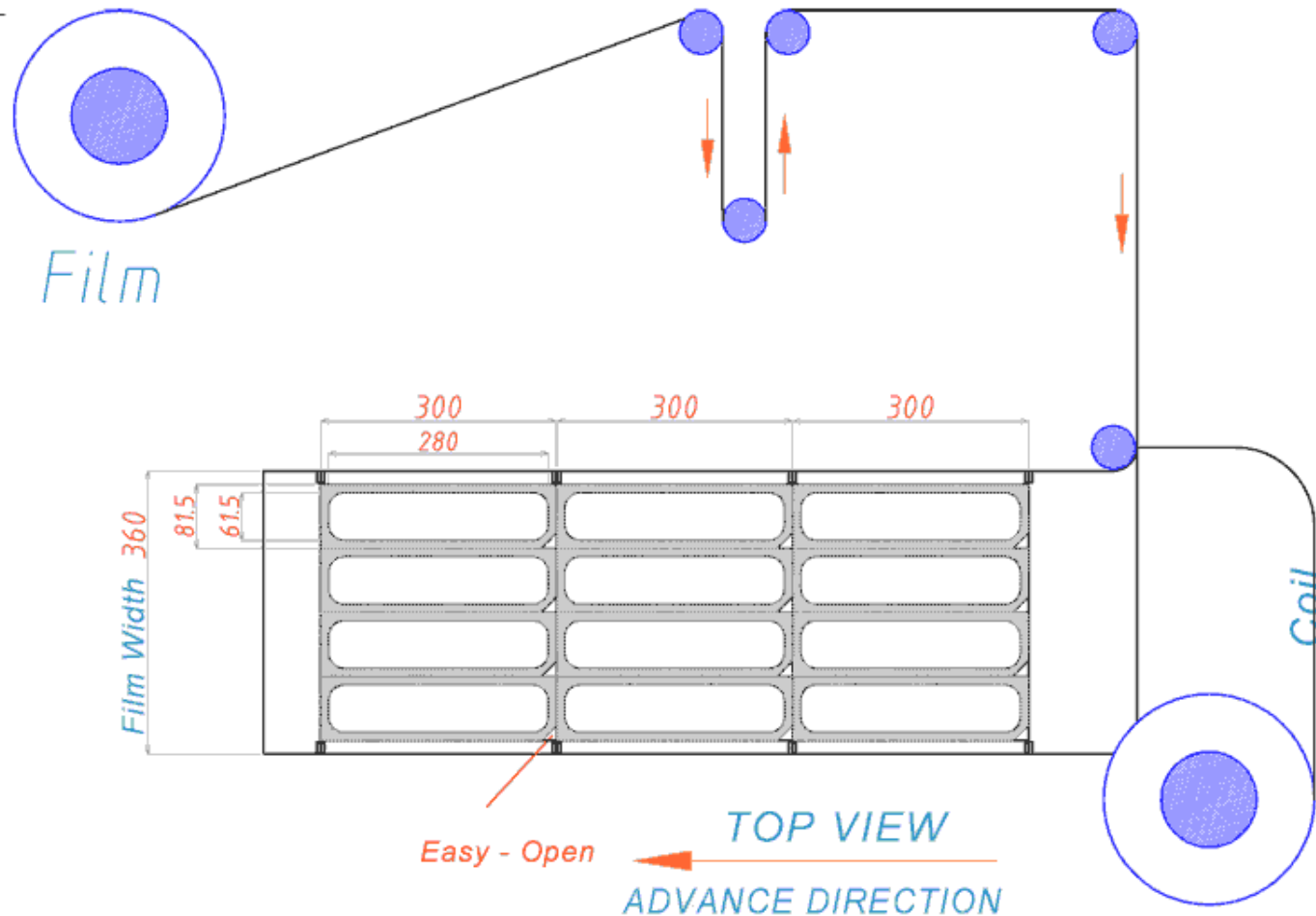

FILM MANUFACTURER SHOULD REQUEST CONTAINER SAMPLES TO THE CUSTOMER TO CHECK MEASURES OF THE RADIUS, WIDTH AND LENGTH OF THE CONTAINERS, AS WELL AS THE CHECKING OF THE EASY OPEN PLACEMENT.

That measures are the real in the machine mechanized - FRIMAQ is not responsible of possibles disturbances in the impressions caused by elongation or shrinkage caused by the quality of the film

Automatic thermoformer

Print project

Serial number : _____

Customer : _____

Mold : 4x2

Width film : 360 mm

Diameter max : 320 mm

Core Ø Int : 76 mm

Tolerances		Printing sign size
Film type	Tolerances per 1m lineal	
Do not stretch	-1 to 3 mm	
Normally Stretch	-2 to 5 mm	
Very soft	-4 to -8 mm	Colour: Black

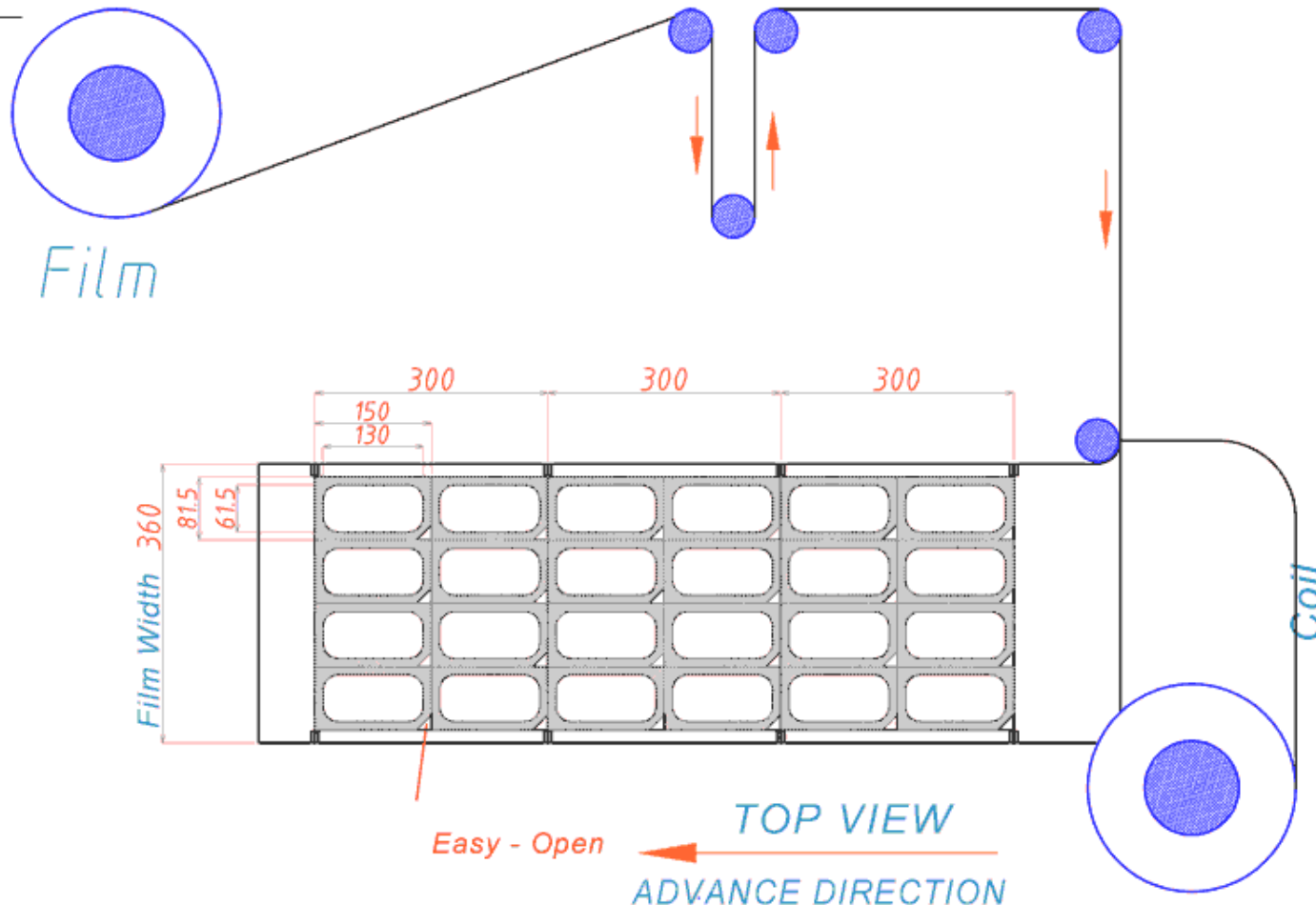

FILM MANUFACTURER SHOULD REQUEST CONTAINER SAMPLES TO THE CUSTOMER TO CHECK MEASURES OF THE RADIUS, WIDTH AND LENGTH OF THE CONTAINERS, AS WELL AS THE CHECKING OF THE EASY OPEN PLACEMENT.

That measures are the real in the machine mechanized - FRIMAQ is not responsible of possibles disturbances in the impressions caused by elongation or shrinkage caused by the quality of the film