

MODEL VCC PLUS

CONTINUOUS VACUUM with BELT

BIACTIVE SEALING
SYSTEM WITH CUT
AND REFRIGERATED

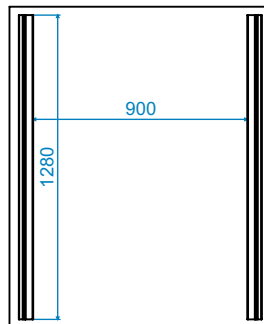
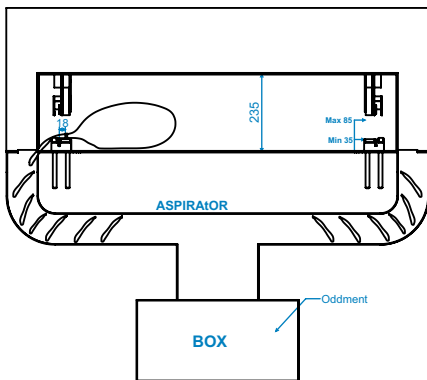
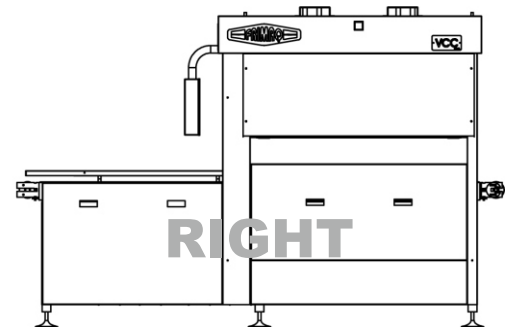
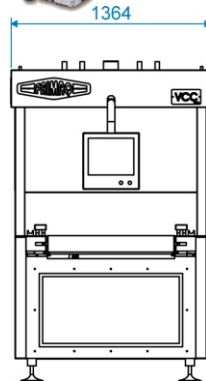
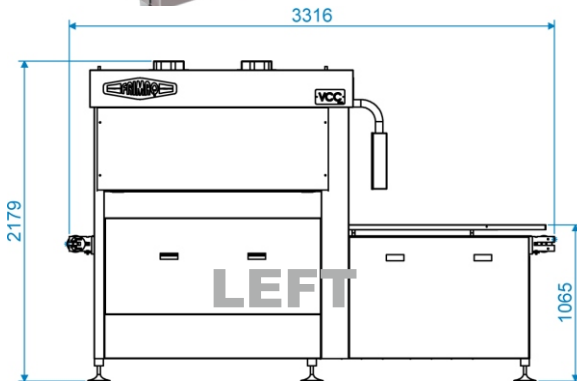
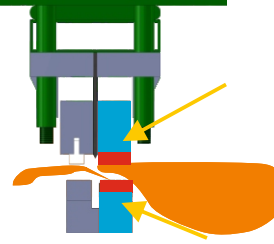

FEATURES

CAN INSTALL BOTH LEFT AND RIGHT SIDES
VACUUM PACKAGING ALL TYPES OF PRODUCTS AND SIZES
PLC AND TOUCHSCREEN SIEMENS
25 PROGRAMS FOR VARIOUS PACKAGED
VACUUM SENSOR, TIME OR BOTH AT THE SAME TIME
INTERMITTENT VACUUM
NO VACUUM REACH ALARM
SOFT-AIR: MILD INTERMITTENT AIR FILLING
RETRACTABLE NON-RETRACTABLE VACUUM BAGS
OPERATING MODE MANUAL, SEMI-AUTOMATIC AND AUTOMATIC
SPECIAL SOLDERING FOR OIL, BLOOD, GREASE, ETC ...
MAKE THE VACUUM TO THE BAG THAT GOES OUTSIDE OF THE CHAMBER
STANDARD HOOD HEIGHT 235 mm (OTHER OPTIONS)
ACTIVATION-DEACTIVATION OF SURPLUS CUT
REMNANTS EVACUATION BY VACUUM AND BLOW
TAPE ADVANCE RAMP NORMAL, SOFT AND VERY SOFT
SPEED 2 TO 3 CYCLES PER MINUTE ACCORDING PUMP, MOISTURE AND TEMPERATURE OF THE PRODUCT
RUNNING ORDER BY INFRARED

CHARACTERISTICS

SECURITIES ACCORDING TO CE STANDARS.
PNEUMATIC SMC.
STAINLESS STEEL FRAME DESIGN LAST.
LEVEL AND HEIGHT FOOT ADJUSTMENT
SIDE DOOR FOR EASY ACCESS TO SERVICE.
BELT POWERED BY MOTO-DRUM.
Easy to clean, SUITABLE FOR FOOD PRODUCTS.
BOARD OF SILICONE BELL-SHAPED LIP, which seals HOOD.
NO NEED FOR PRESSURE.
EASY COVER BOARD CHANGE WITHOUT ADHESIVE OR TOOLS.
INTERIOR BUILDING FRAME FOR VACUUM PUMPS AND PUMPS ROOTS.
Air consumption: 200 liters / minute / 6 bar pressure.
MAXIMUM POWER: ACCORDING BOMBS.
TOTAL WEIGHT NOT BOMBS 2250 Kgs.